

THANKS FOR BUYING THE RJ SPEED OUTLAW SPRINTER KIT. IT IS COMPLETE LESS ELECTRICS, AND MADE FOR CARPET OR PAVEMENT RACING. IT REQUIRES A 540 OR 550 SIZE MOTOR, 4 OR 6 CELL BATTERY PACK, TWO CHANNEL RADIO WITH ESC, AND A SERVO SAVER TO FIT THE BRAND OF RADIO YOU HAVE CHOSEN. THE TOOLS YOU WILL NEED ARE A SMALL PAIR OF PLIERS, A 1/4 " SOCKET OR WRENCH, AND A 7/16 " SOCKET WRENCH FOR THE DIFFERENTIAL. HEX WRENCHES TO FIT THE SOCKET HEAD SCREWS ARE INCLUDED IN THE KIT. YOU WILL ALSO NEED PAINT MADE FOR LEXAN FOR THE BODY PARTS AND WINGS. REFER TO THE TEXT AND PICTURES FOR EACH STEP , AND ALSO THE EXPLODED VIEW DRAWING FOR THE CHASSIS ASSEMBLY AND PARTS REFERENCE AND THE WING TRIM AND ASSEMBLY DRAWINGS

IT IS BEST TO READ EACH STEP THROUGH, LOOK AT THE PICTURES, DRAWINGS,AND PARTS , THEN DO THE ASSEMBLY STEP.

YOUR KIT CONTAINS THE FOLLOWING:

- | | |
|------------------------|-------------------|
| BAG H1 CHASSIS KIT | BAG L5 REAR TIRES |
| BAG H3 HARDWARE | 1043 BODY PARTS |
| BAG L2 REAR AXLE PARTS | 1525 WING PARTS |
| BAG L4 FRONT TIRES | INSTRUCTION PKG. |

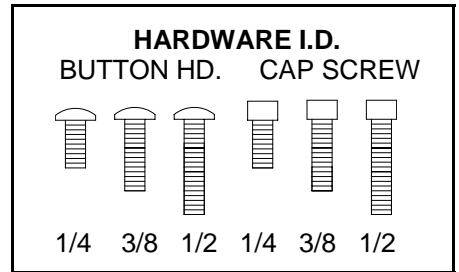

STEP 1 OPEN BAG H1 AND H1A. ATTACH THE 5065 NERF BARS TO THE CHASSIS SIDES WITH 3/8 CAP SCREWS. REFER TO THE HARDWARE ID FOR SCREW SIZES. INSERT THE SCREW FOR THE REAR OF THE LEFT NERF BAR THRU THE TIE BAR , THEN THE CHASSIS AND INTO THE NERF BAR.

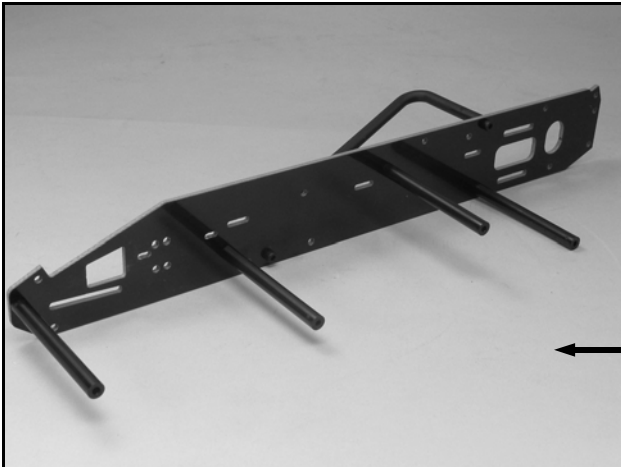
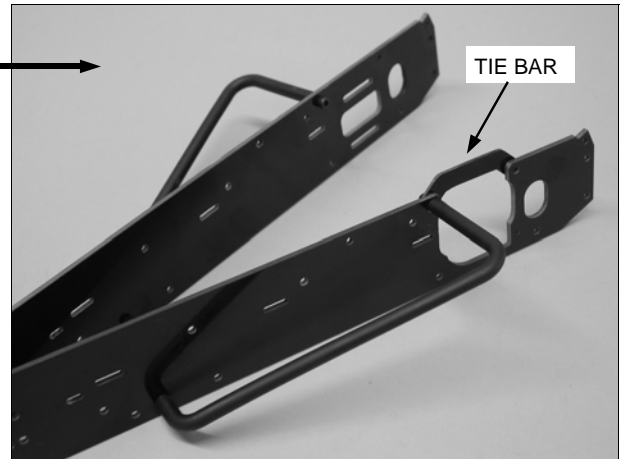

STEP 2 ATTACH FOUR 5245 CHASSIS SPACERS TO THE RIGHT CHASSIS SIDE WITH 3/8 CAP SCREWS. USE A 3/8 BUTTON HEAD ON THE FRONT ONE.

STEP 3 SLIDE THE FRONT AXLE PLATE, SERVO TRAY AND RADIO TRAY INTO THE SLOTS IN THE CHASSIS SIDE.

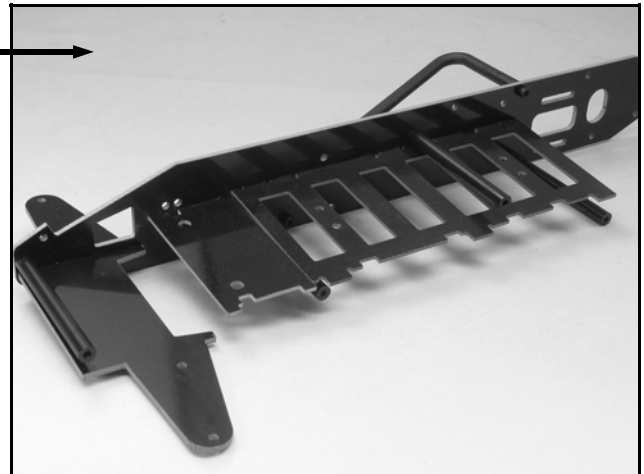

STEP 4 SLIDE THE LEFT CHASSIS OVER THE PARTS AND ATTACH WITH 3/8 CAP SCREWS (BUTTON HD. ON FT.).SET THE CHASSIS ON YOUR TABLE TO MAKE SURE IT SITS FLAT. IF NOT, HOLD BOTH ENDS AND TWIST TO CORRECT. CHECK IT AGAIN AFTER INSTALLING THE REAR BARS AND CAGE.

STEP 5 ATTACH THE REAR BARS AND CHASSIS SPACERS TO THE REAR OF THE CHASSIS WITH FOUR 1/2" BUTTON HEAD SCREWS.

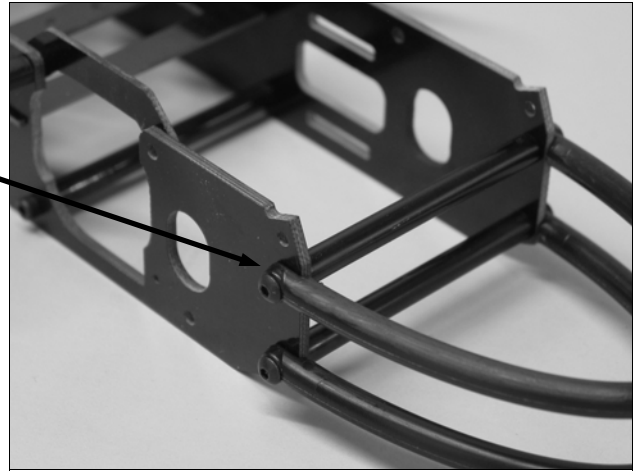
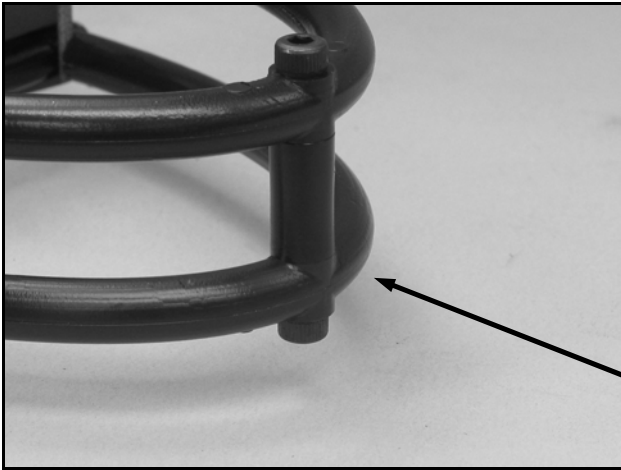

STEP 6 USE TWO 1/2" CAP SCREWS AND THE 1/2" NYLON SPACER TO ATTACH THE REAR BARS TOGETHER.

STEP 7 OPEN THE STEERING BAG FROM BAG H1 AND THREAD A JAM NUT ON EACH 5377 KINGPIN, INSERT INTO EACH END OF THE FRONT AXLE PLATE, AND ADD A 7207 LOCKNUT ON EACH ONE.

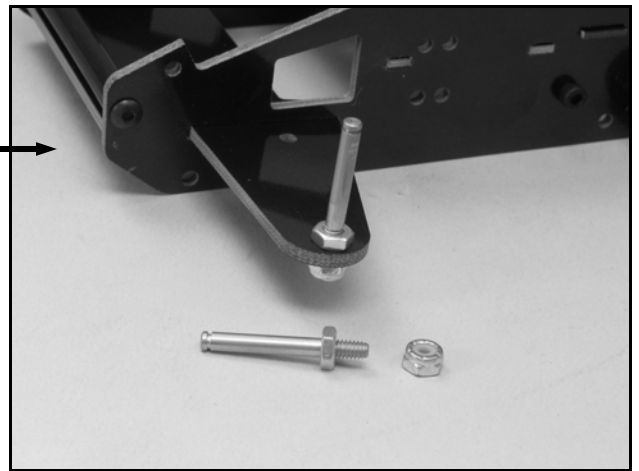
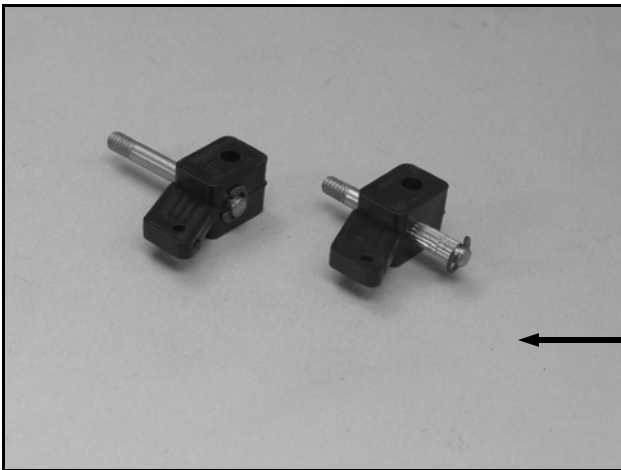

STEP 8 PRESS A 5364 STUB AXLE INTO EACH 5351 STEERING BLOCK AND RETAIN WITH A 5221 E-CLIP.

STEP 9 LUBE EACH KINGPIN, SLIDE THE STEERING BLOCK ON, ADD A 5228 SPRING, WASHER, AND E-CLIP.

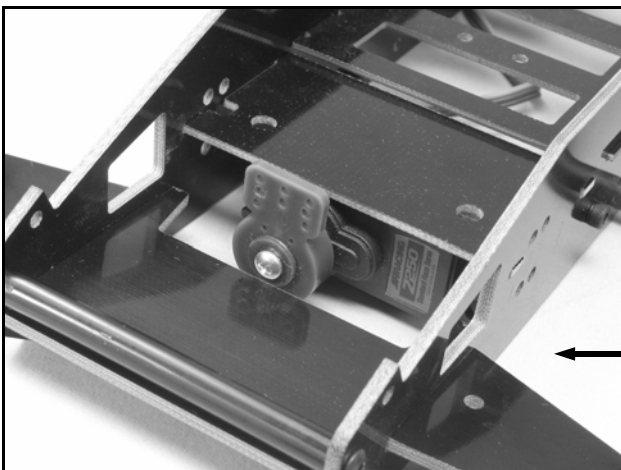
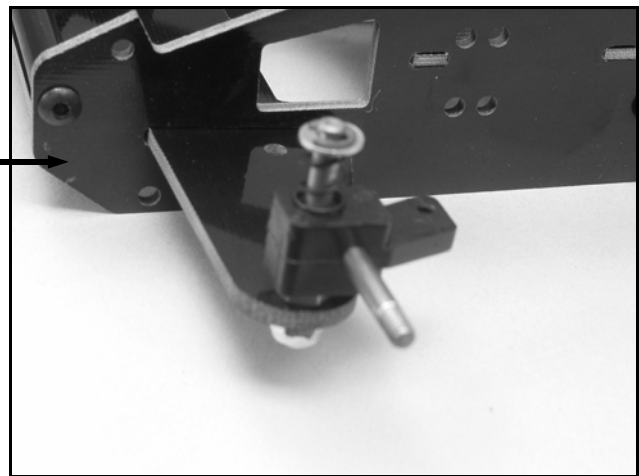

STEP 10 INSTALL YOUR SERVO SAVER ON THE SERVO AND ATTACH THE SERVO UNDER THE SERVO PLATE WITH FOAM TAPE PROVIDED. GET THE SERVO SAVER AS CLOSE TO THE CENTER AS POSSIBLE. MAKE SURE TO WIPE THE SERVO AND SERVO PLATE WITH A DRY CLOTH BEFORE APPLYING THE TAPE.

STEP 11 INSTALL THE STEERING LINKAGE FROM BAG H3. INSTALL A LONG LINK IN EACH STEERING BLOCK AND TWO SHORT ONES IN THE SERVO SAVER. USE THE COLLARS AND SET SCREWS TO ATTACH THE RODS TOGETHER AFTER ALIGNING THE STEERING.

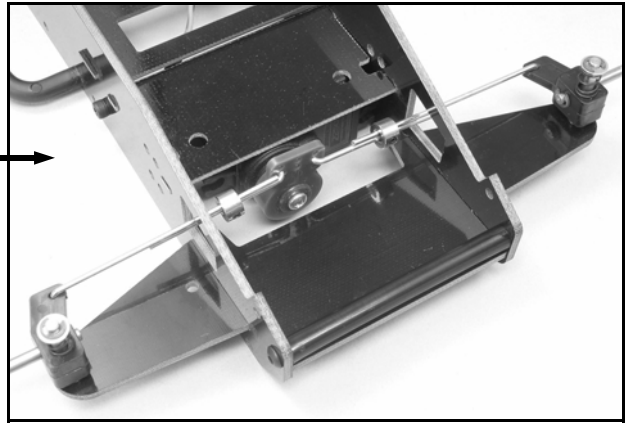
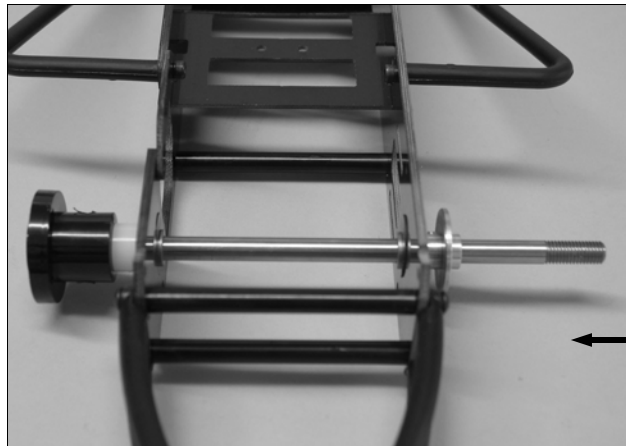
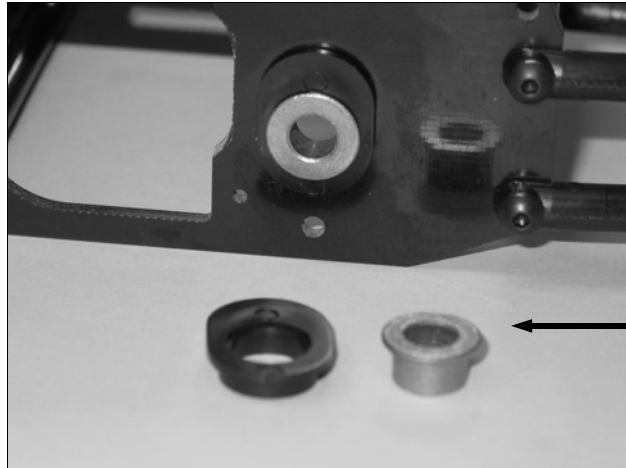

STEP 12 INSTALL THE 5188 RIDE HEIGHT ADAPTORS FROM BAG L2 AND ADD THE 5452 REAR BUSHINGS.

STEP 13 SNAP A DIFF BALL INTO EVERY OTHER HOLE IN THE OUTSIDE ROW OF THE GEAR. LUBE EACH ONE WITH A LITTLE THICK SILICONE OR GREASE.



STEP 14 INSTALL A THIN NYLON AXLE WASHER ON THE AXLE, SLIDE THE AXLE THRU THE BUSHINGS, THEN ADD THE 1/4" AXLE SPACER AND 5311 HUB WITH SETSCREWS LEAVE A SMALL AMOUNT OF SIDEPLAY IN THE AXLE. ADD A DROP OF LIGHT OIL INSIDE EACH BUSHING. TIGHTEN EACH SETSCREW A LITTLE A TIME TO KEEP FROM WARPING THE HUB. YOU CAN FILE A FLAT SPOT ON THE AXLE WHERE EACH SETSCREW HITS TO MAKE IT MORE SECURE.

STEP 15 ASSEMBLE THE DIFF BY INSTALLING ONE DRIVE RING ON THE AXLE, THE GEAR, SECOND DRIVE RING AND ALUM. ADAPTOR, 5309 HUB, THIN STEEL WASHER, THRUST BEARING, THICK STEEL WASHER, (OR TWO THIN), CONE WASHER, AND DIFF NUT. TIGHTEN THE NUT TO REMOVE SIDEPLAY, AND ADJUST UNTIL YOU CAN HOLD BOTH HUBS AND THE GEAR DOES NOT SLIP EASILY.

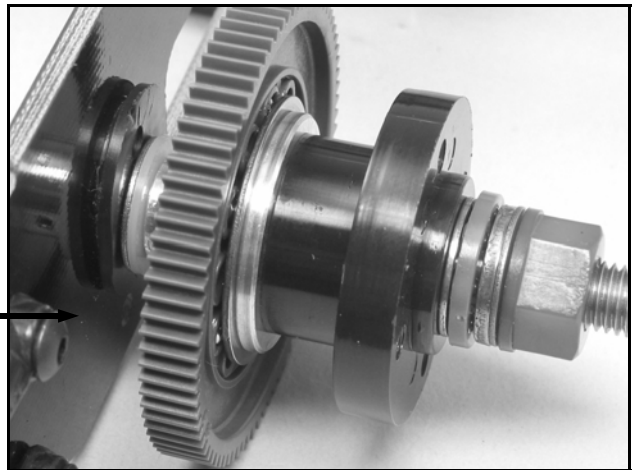
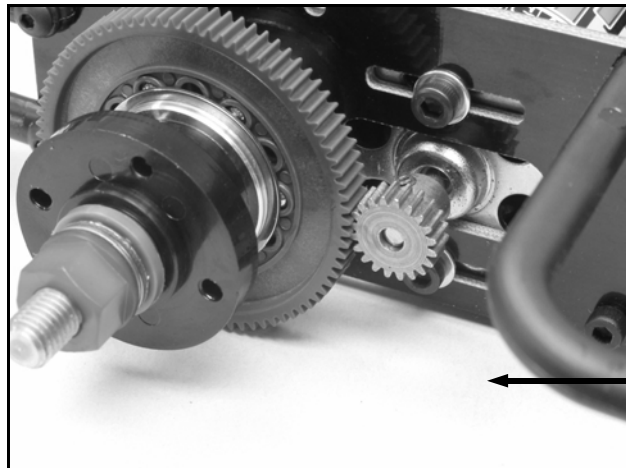

STEP 16 INSTALL THE MOTOR YOU HAVE PURCHASED WITH M3 SCREWS AND WASHERS FROM BAG H3. INSTALL THE GEAR WITH THE SETSCREW AND MAKE SURE IT LINES UP WITH THE DIFF GEAR. SLIDE THE MOTOR BACK UNTIL YOU HAVE A VERY SMALL AMOUNT OF PLAY BETWEEN THE GEARS. TIGHTEN THE MOTOR SCREWS, TURN THE AXLE A COUPLE OF TIMES, CHECK THE GEAR MESH, AND READJUST IF NECESSARY.

STEP 17 INSTALL YOUR SPEED CONTROL AND RECEIVER ON TOP OF THE RADIO TRAY WITH FOAM TAPE. MAKE SURE TO LEAVE ROOM TO USE TIE STRAPS IN A COUPLE OF THE SLOTS AT THE EDGE OF THE TRAY TO HOLD THE BATTERY PACK UNDER IT.

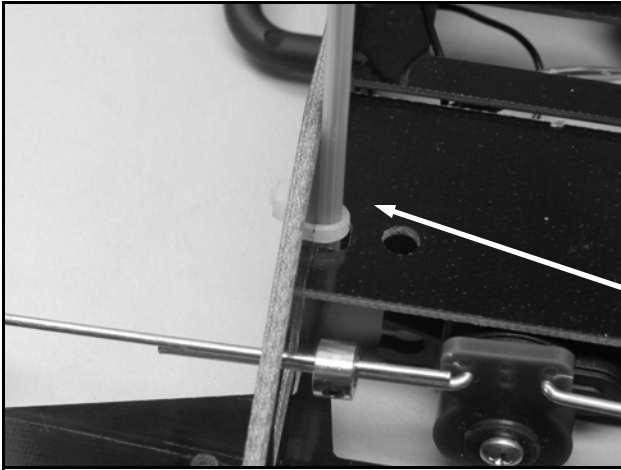
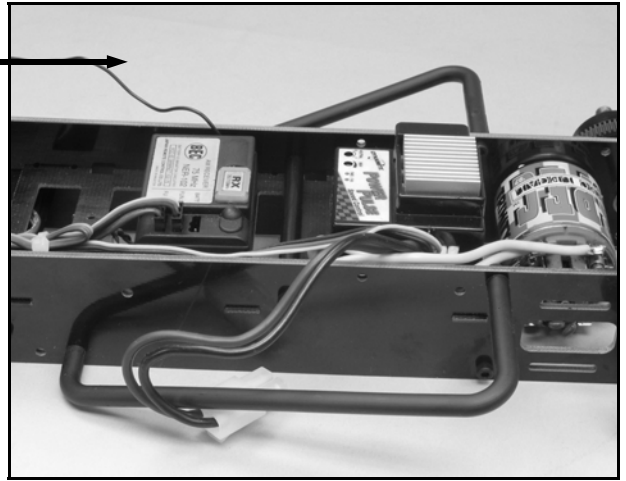

STEP 18 IF YOUR RADIO HAS A LONG ANTENNA WIRE AND REQUIRES A SUPPORT TUBE, OBTAIN ONE FROM YOUR LOCAL HOBBY SHOP AND INSTALL THE ANTENNA TUBE ON THE INSIDE OF THE CHASSIS THRU THE SERVO PLATE WITH TWO SMALL TIE STRAPS. ROUTE YOUR ANTENNA WIRE THRU THE TUBE FROM THE BOTTOM. PLUG YOUR SPEED CONTROL AND SERVO INTO THE RECEIVER, GATHER ALL THE EXCESS WIRE (INCLUDING ANTENNA WIRE) AND TAPE IT IN PLACE NEAR THE RECEIVER. SOLDER OR CONNECT YOUR SPEED CONTROL WIRES TO THE MOTOR. YOU SHOULD CHARGE YOUR BATTERY AND TEST YOUR RADIO FUNCTIONS AND MAKE ADJUSTMENTS NOW.



STEP 19 INSTALL YOUR BATTERY PACK UNDER THE RADIO TRAY WITH A TIE STRAP. YOU SHOULD HAVE ROOM TO MOUNT YOUR SWITCH NEXT TO IT WITH SERVO TAPE SO YOU CAN TURN THE CAR ON AND OFF WITHOUT REMOVING THE BODY. YOU CAN ALSO MOUNT THE SWITCH NEXT TO THE SERVO IF YOU HAVE ROOM.

STEP 20 OPEN BAG H1A. MOUNT THE ROLL CAGE SIDES TO THE CHASSIS WITH 3/8 BUTTON HEAD SCREWS. USE THE 1/4" (SHORT) SCREWS IN THE FRONT HOLES. ADD THE JAM NUT FROM BAG A AT THE REAR OF THE TIE BAR.

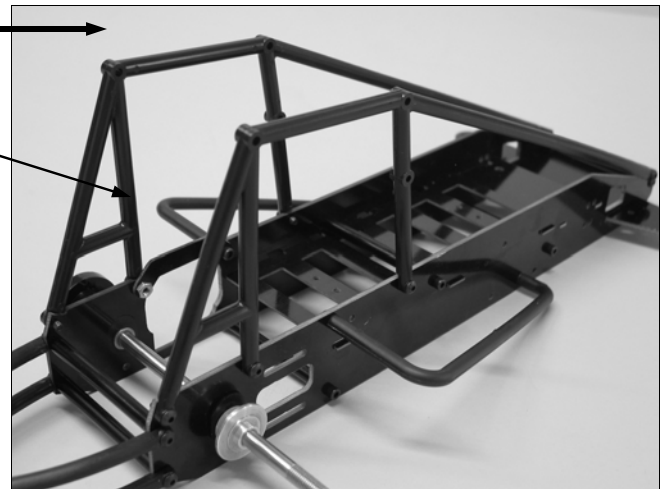
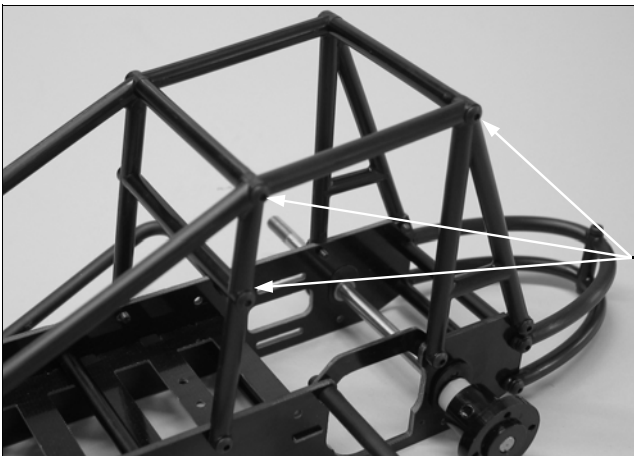

STEP 21 USE 1/2" BUTTON HEAD SCREWS AND THREE CHASSIS SPACERS TO ATTACH THE TWO SIDES OF THE ROLL CAGE TOGETHER. THE TOP TWO WILL ALSO BE USED TO HOLD THE WING MOUNTS ON LATER.

STEP 22 PAINT THE HOOD AND TAIL TANK PARTS AND THE SIDE PANELS AND TRIM THEM OUT AS SHOWN. DRILL THE HOLES MARKED WITH A 1/8" DRILL TO MOUNT THEM TO THE CHASSIS. THE TWO HOLES IN THE SIDES OF THE TAIL TANK SNAP OVER THE TWO SCREWS THAT HOLD THE REAR OF THE ROLL CAGE TO THE CHASSIS AND YOU WILL NEED TO REMOVE THE BOTTOM SCREW THAT HOLDS THE LOWER REAR BAR TO THE 1/2" SPACER TO ATTACH THE REAR OF THE TAIL TANK.

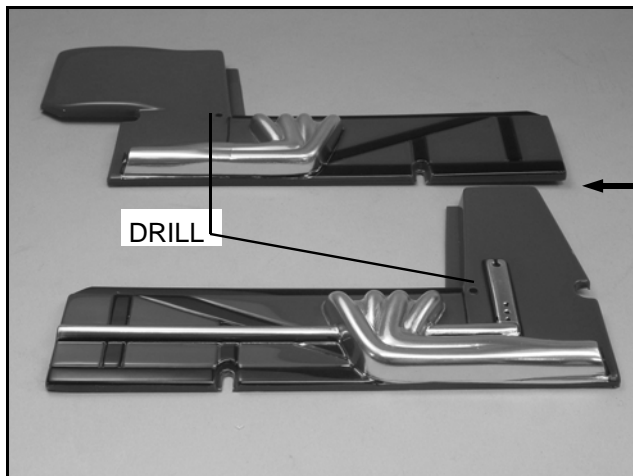

STEP 23 TO MOUNT THE SIDE PANELS, LOOSEN THE SCREWS THAT HOLD THE FRONT OF THE NERF BARS AND REMOVE THE SCREWS THAT ATTACH THE CENTER OF THE ROLL CAGE TO THE CHASSIS. SLIDE THE SIDE PANEL OVER THE REAR OF THE NERF BAR AND BETWEEN THE FRONT OF THE NERF BAR AND THE CHASSIS. TIGHTEN THE FRONT NERF BAR SCREW AND REPLACE THE 1/4" SCREW TO HOLD THE SIDE PANEL IN PLACE. REPEAT FOR THE OPPOSITE SIDE. TO INSTALL THE HOOD, SLIDE IT BETWEEN THE CAGE SIDES AND SPREAD IT OUT SO IT WILL GO OVER THE SIDE PANEL FLANGES. TRIM SLIGHTLY IF NECESSARY. YOU CAN USE TAPE OR VELCRO TO HOLD THE REAR OF THE HOOD OVER THE CHASSIS BRACE IF NEEDED.

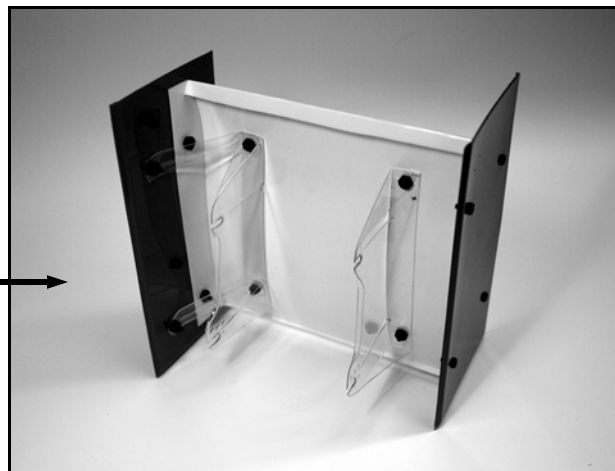
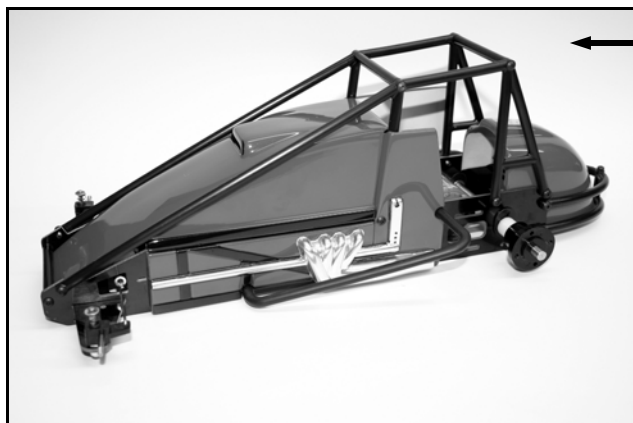

STEP 24 CUT OUT YOUR WINGS & SIDE DAMS AND BRACES FROM THE WING PARTS SHEETS AS SHOWN ON THE WING DRAWING AND PAINT THEM AS YOU WISH. DRILL HOLES AS SHOWN IN THE DRAWINGS. ASSEMBLE THE REAR WING MOUNTS, SIDE DAMS, AND BRACES TO THE LARGE WING WITH SMALL SCREWS AND NUTS PROVIDED.

THERE ARE SEVERAL SETS OF HOLES AT THE BOTTOM OF THE WING MOUNTS TO MOVE THE LOCATION AND ANGLE OF THE WING ON THE CHASSIS.

STEP 25 ASSEMBLE THE SIDE DAMS TO THE FRONT WING AND CUT OUT THE MOUNT FROM THE LEXAN SHEET AS SHOWN IN THE WING PARTS DRAWING. BEND IT AS SHOWN AND USE SERVO TAPE TO ATTACH IT TO THE UNDERSIDE OF THE WING AND TO ATTACH IT TO THE FRONT OF THE HOOD.

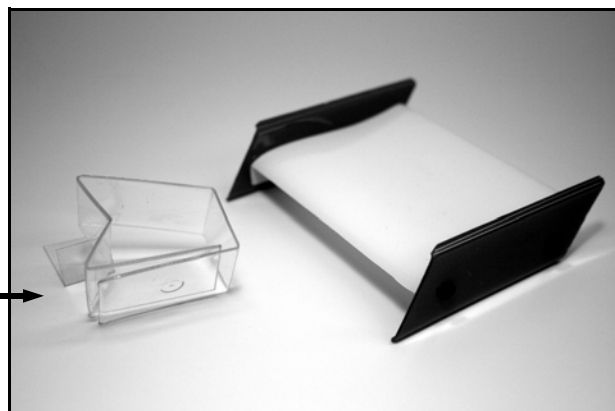

STEP 26 WITH THE FRONT WING MOUNTED ON THE HOOD , YOU CAN BEND THE FRONT PORTION OF THE MOUNT TO CHANGE THE WING ANGLE FOR MORE OR LESS STEERING.

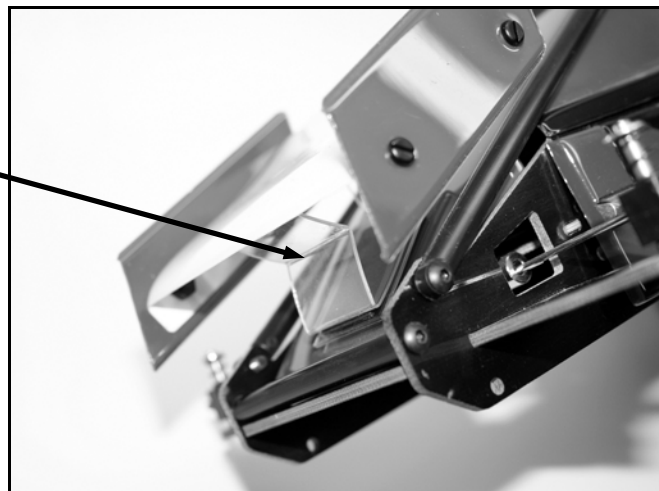
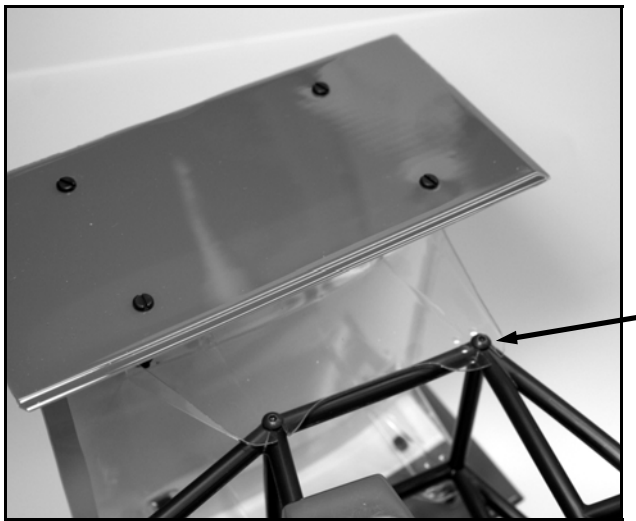

STEP 27 INSTALL THE REAR WING TO THE ROLL CAGE WITH THE SCREWS THAT ATTACH THE CHASSIS BRACES . YOU CAN SLOT THE HOLES IN THE MOUNTS FOR EASY REMOVAL, BUT THE WING MAY NOT STAY ON AS WELL IN A HARD CRASH.



STEP 28 PRESS THE BUSHINGS FROM BAG H3 INTO EACH SIDE OF EACH FRONT WHEEL FROM BAG L4. LUBE THE FRONT AXLES WITH LIGHT OIL AND INSTALL THE FRONT WHEELS. ADD LOCK-NUTS FROM THE STEERING BAG TO HOLD THEM ON. TIGHTEN THEM LIGHTLY, THEN BACK THEM OFF UNTIL THE WHEELS SPIN FREELY. INSTALL THE REAR TIRES FROM BAG L5 TO THE REAR HUBS WITH TWO 3/8 CAP SCREWS EACH FROM THE DIFF BAG. THE TIRES IN YOUR KIT MAY VARY FROM THE ONES SHOWN. THEY WILL BE OF THE SAME OR BETTER QUALITY.

NOW YOU'RE READY FOR THE FUN PART . CHARGE YOUR BATTERY AND CHECK OUT YOUR STEERING AND THROTTLE TO MAKE SURE IT'S ADJUSTED CORRECTLY. SET THE CAR DOWN IN AN OPEN AREA ,AND HIT THE THROTTLE A COUPLE OF TIMES TO SEE IF IT RUNS STRAIGHT. ADJUST THE RADIO TRIM AS NEEDED BEFORE TRYING TO RUN AT SPEED .ADJUST THE DIFF WITH THE RED NUT SO THAT IT SLIPS A SMALL AMOUNT BEFORE THE CAR TAKES OFF. DEPENDING ON THE MOTOR AND BATTERY YOU HAVE CHOSEN, THE CAR MAY BE VERY FAST. MAKE SURE YOU ARE IN A LARGE , OPEN AREA. THIS SPRINTER IS BUILT WELL, BUT CAN BE BROKEN IF DRIVEN INTO SOLID OBJECTS REPEATEDLY AT HIGH SPEED. REPLACEMENT PARTS AND ACCESSORIES ARE AVAILABLE THROUGH YOUR LOCAL HOBBY SHOP. HAVE FUN WITH YOUR RJ SPEED SPRINTER!!

www.rjspeed.com

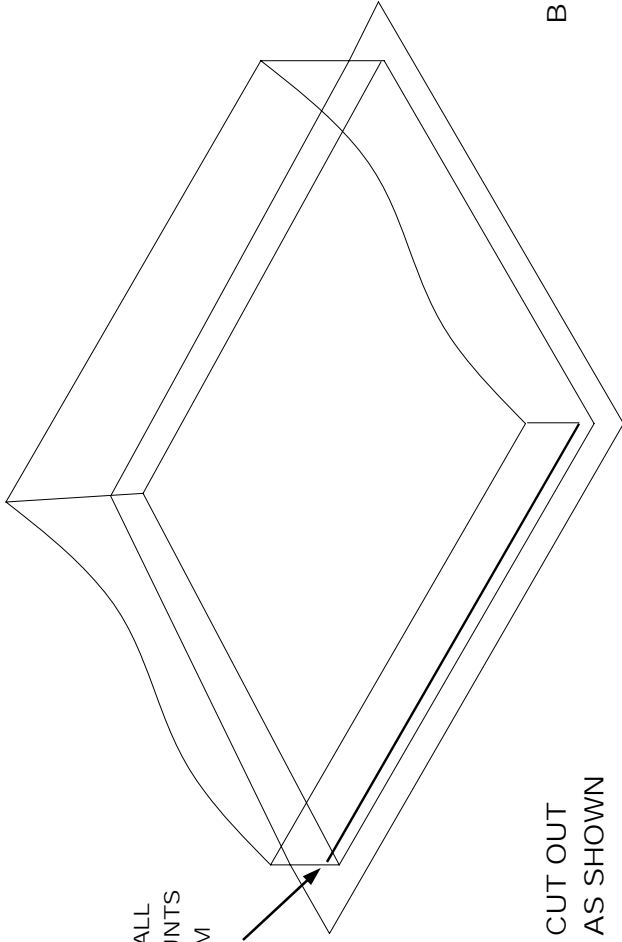
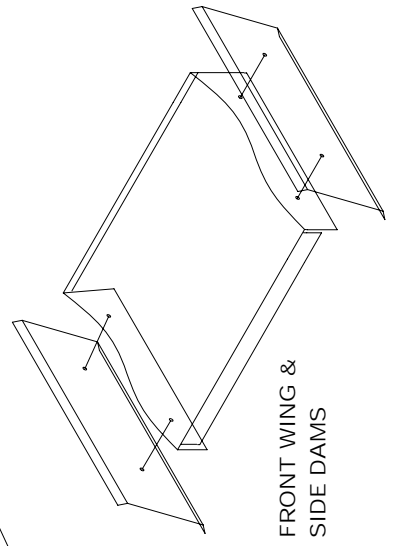
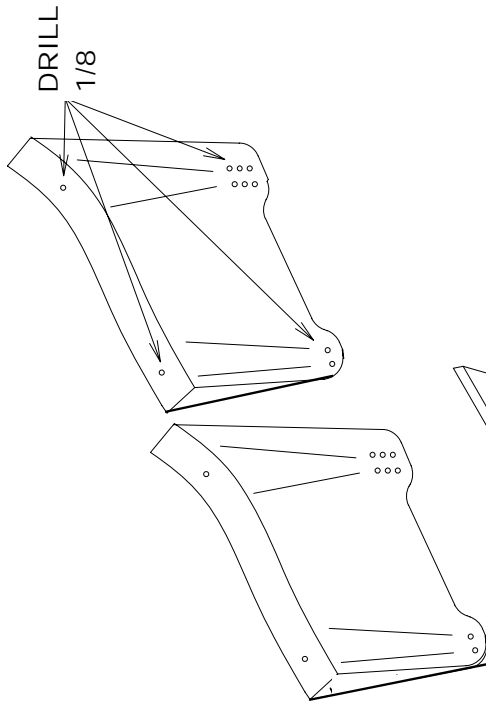
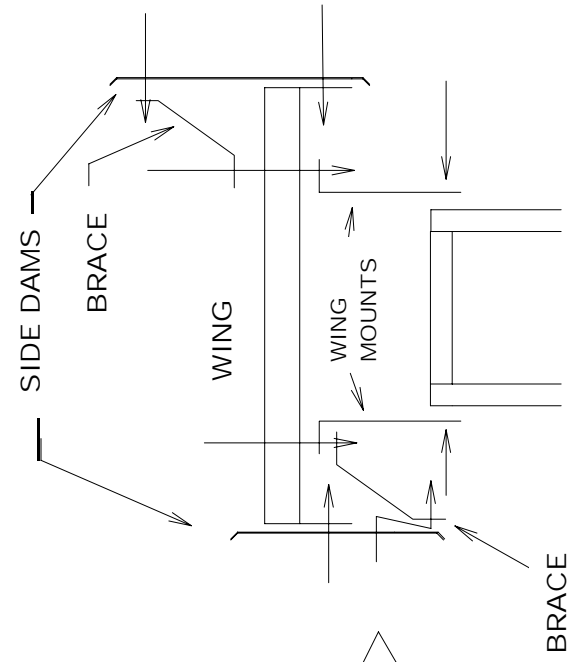

TRIM LARGE AND SMALL WING AND WING MOUNTS ABOUT 1/8 INCH FROM THE BOTTOM.

BEND HERE TO ADJUST FRONT WING ANGLE

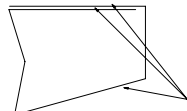
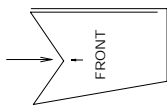

USE SERVO TAPE TO ATTACH THE MOUNT TOGETHER AND TO ATTACH IT TO THE FRONT WING AND THE FRONT OF THE HOOD

FRONT WING MOUNT CUT OUT OF SHEET AND FOLD AS SHOWN

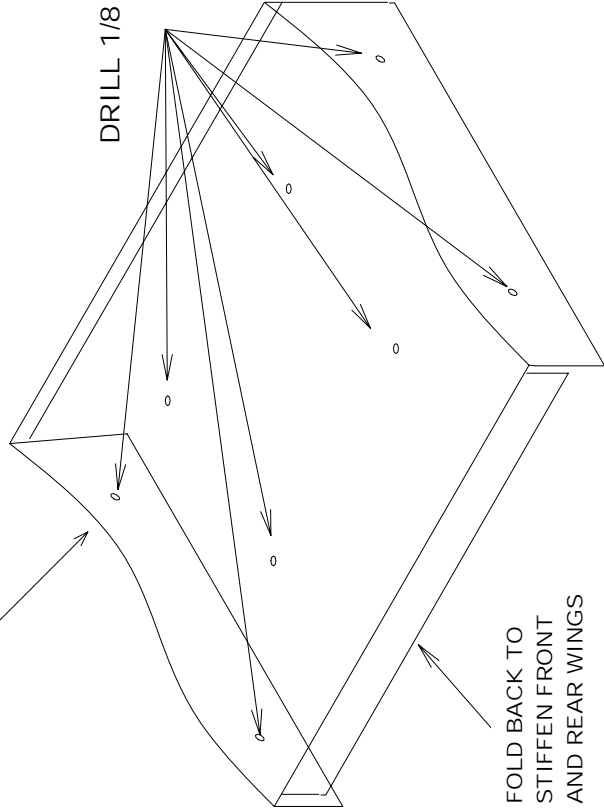

FOLD BACK TO STIFFEN FRONT AND REAR WINGS



2030 OUTLAW SPRINTER

REPLACEMENT PARTS

- 1043 BODY PARTS SET
- 1525 WING KIT W/SCREWS
- 2520 FRONT SPEC TIRES (2)
- 2530 REAR SPEC TIRES (2)
- 5060 CHASSIS, MOTOR SIDE
- 5061 CHASSIS, L.SIDE/TIE BAR
- 5062 RADIO TRAY
- 5063 SERVO PLATE
- 5064 ROLL CAGE/ REAR BARS
- 5065 NERF BARS (2)
- 5188 AXLE HEIGHT ADAPT (2 PR)
- 5221 E-CLIPS (6)
- 5228 FRONT SPRINGS (2)
- 5244 FRONT AXLE PLATE
- 5245 CHASSIS SPACERS (6)
- 5308 STEERING LINKAGE
- 5351 STEERING BLOCKS (2)
- 5364 STUB AXLES (2)
- 5377 KINGPINS (2)
- 5452 REAR BUSHINGS (2)
- 5457 FRONT BUSHINGS (4)

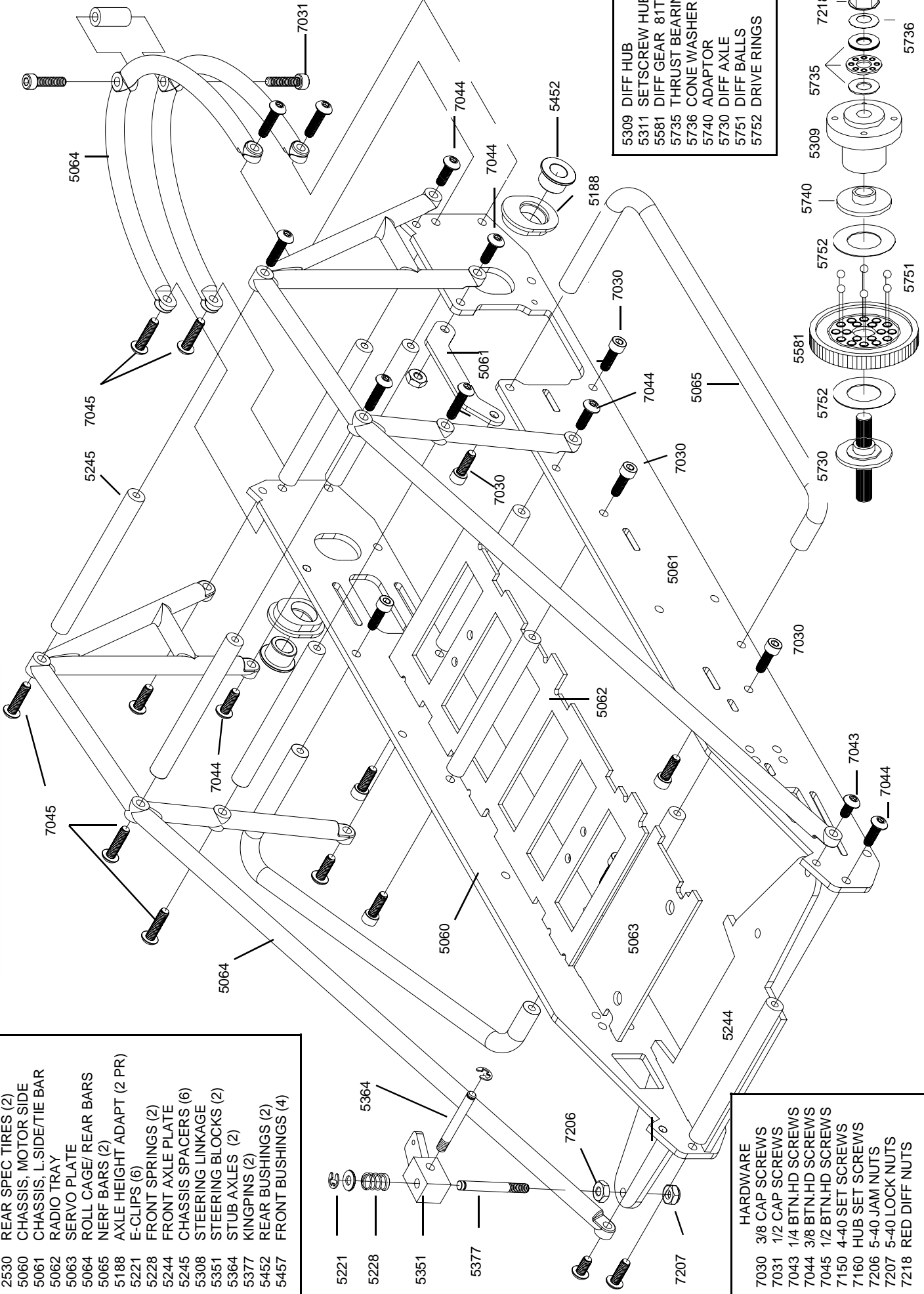

- 5309 DIFF HUB
- 5311 SETSCREW HUB
- 5581 DIFF GEAR 81T
- 5735 THRUST BEARING
- 5736 CONE WASHER
- 5740 ADAPTOR
- 5730 DIFF AXLE
- 5751 DIFF BALLS
- 5752 DRIVE RINGS

- ### HARDWARE
- 7030 3/8 CAP SCREWS
 - 7031 1/2 CAP SCREWS
 - 7043 1/4 BTN.HD SCREWS
 - 7044 3/8 BTN.HD SCREWS
 - 7045 1/2 BTN.HD SCREWS
 - 7150 4-40 SET SCREWS
 - 7160 HUB SET SCREWS
 - 7206 5-40 JAM NUTS
 - 7207 5-40 LOCK NUTS
 - 7218 RED DIFF NUTS